

Introduction to In-Situ Testing of Structures

Prof. Dr. Azlan Ab. Rahman
Universiti Teknologi Malaysia

MAB 1033 Structural Assessment & Repair
Faculty of Civil Engineering

Great Liability of the Engineer

“The great liability of the engineer...compared to men of other professions...is that his works are out in the open, where all can see them.

His acts ...step by step...are hard substance.

He cannot bury his mistakes in the grave like doctors.

He cannot argue them into thin air ...or blame the judge ...like the lawyers.

He cannot, like the architect, cover his failures with trees and vines.

He cannot, like the politicians, screen his shortcomings by blaming his opponents...and hope that people will forget.

The engineer simply cannot deny he did it.

If his works do not work...he is damned.”

Herbert Hoover

Clinton Hill Building Collapse

Monday, June 22, 2009



The four-storey building at 493 Myrtle Avenue in Clinton Hill collapsed Sunday afternoon, somehow resulting in no serious injuries. The Local blog notes that the building was recently cited by the DOB for some structural issues, including a big crack running up its east-facing wall. The collapse also damaged the neighboring building at 491 Myrtle Avenue, which will have to be razed.

Collapse of Luxury Apartment Building (The Highland Towers)



Failed Bridge Structures



Member Tom Damiap, right, reaches in to search inside the collapsed structure.



Putrajaya Bridge Collapse



Structural Distress



Life Cycle of a Building

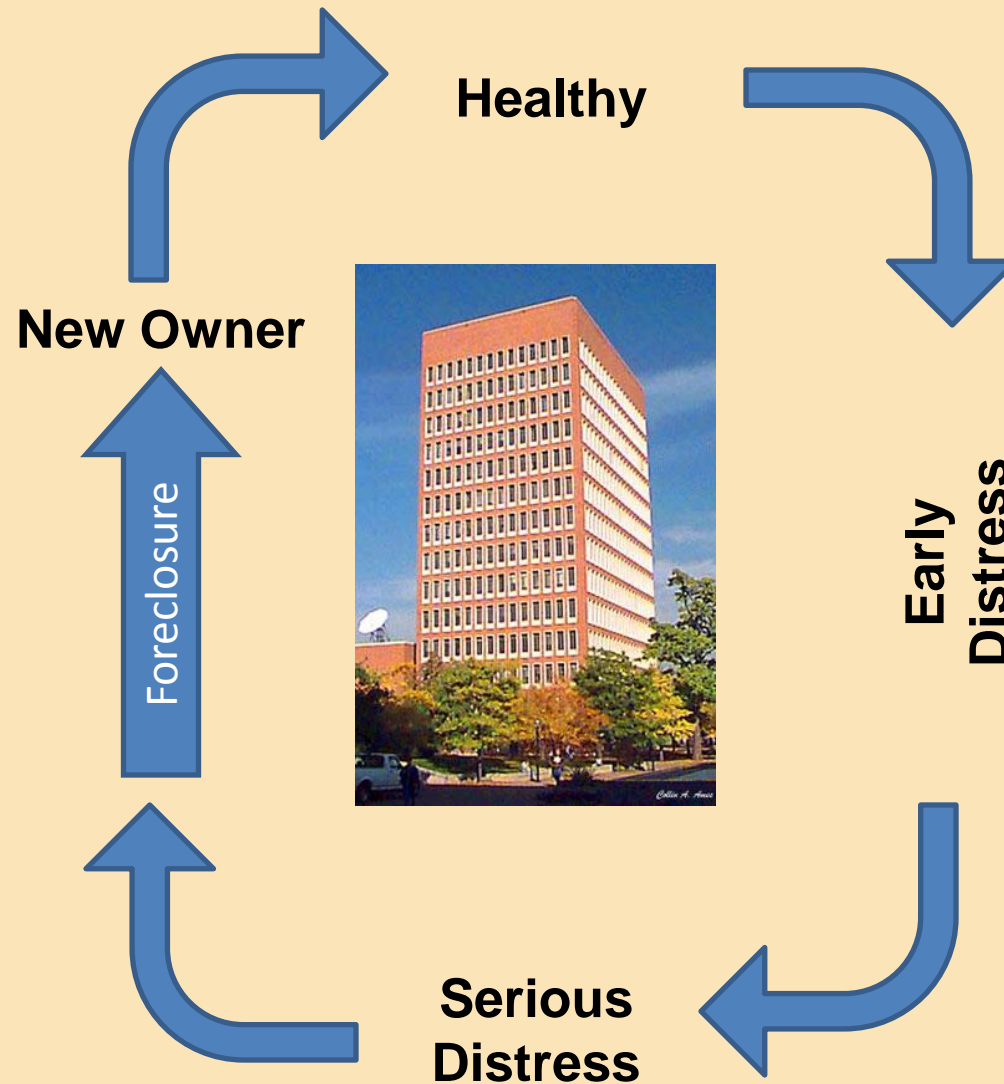

Human Patient vs. Distressed Structure

Human Patient	Distressed Structure
Physical body structure	Building structural form
Health deteriorates due to lack of care or overwork	Condition deteriorates due to lack of maintenance or overload
Patient with health problems / sickness / organs malfunction	Distressed structure / damaged or deteriorated structural members
See a doctor	Consult a structural engineer (inspection, testing, monitoring)
Doctor checks & carries out testing for all symptoms or clues of illness	Structural engineer uses NDT & other test methods to check symptoms of distress
Doctor assesses, analyses and diagnoses cause of health problem	Engineer assesses, analyses and diagnoses cause of building deterioration
Doctor prescribes medication & treatment	Engineer proposes remedial measures / repair & rehabilitation
Doctor proposes health monitoring programme / regular check-ups	Engineer proposes continuous long-term structural health monitoring

Overview



Knowledge on structural distress analysis



Knowledge & application of diagnostic inspection & testing

Structural Assessment

Repair or Rehabilitation
 -Non structural
 -Structural
 -Strengthening
 -Replacement
 - etc.

- Symptoms:
- Cracking
 - Deflection
 - Vibration
 - Spalling
 - Fire damage
 - etc.

Definitions

- An **inspection** is an organised examination or formal evaluation exercise. It involves the measurements, tests, and gauges applied to certain characteristics in regards to an object or activity.
- The results are usually **compared to specified requirements and standards** for determining whether the item or activity is in line with these targets. Inspections are usually non-destructive.

Purpose of Inspection

- The main purpose of inspection is **to ensure that safety standards are adhered to**, both at the public and personal level. During the investigation, if the inspector notices low standards, **corrective measures** are taken immediately.
- Inspections such as home inspections and building inspections are highly beneficial to owners as well as to buyers who plan to make huge investments. In all inspections, **standards of compliance** in accordance with the state are ensured.
- A good inspection **guarantees public safety** by enforcing municipal and state regulations typically for construction activities.

Definitions

- Non-Destructive Evaluation (NDE)
- Non-Destructive Testing (NDT)
- Non-Destructive Inspection (NDI)
- These terms describe testing that does not destroy the test object and involves a number of technologies used to analyze materials for either inherent flaws or damage from use.

Reasons for Structural Testing

- To determine strength.
- To carry out a comparative quality survey – condition survey.
- To examine localised integrity.
- To assess potential durability.
- To identify causes & extent of deterioration

Basis of Structural Investigation

- Quality control procedure.
- Assessing non-compliance of specimens.
- Uncertainties in quality of workmanship.
- Monitoring strength development.
- Assessing load carrying capacity for upgrading or change of loading.
- Suspected or observed deterioration or distress.
- Regular maintenance inspection.
- Determining cause of failure or defects (Forensic Engineering)

Scope of Assessment *

- **Strength Assessment** – assessment of concrete strength;
- **Durability Assessment** – identifying nature & extent of observed or suspected deterioration including reinforcement corrosion;
- **Integrity Assessment** – determination of localised integrity or generalised assessment of behaviour of whole structure.

* Bungey, J.H., 'The Testing of Concrete in Structures' 2nd. Edition, Blackie Academic & Professional, Chapman & Hall, London 1994

Category of NDT Techniques

- **Near-to-Surface** : semi-destructive or partially-destructive. (e.g. surface hardness, penetration resistance, in-situ permeability, corrosion risk measurement)
- **Internal Testing** : non-destructive. (e.g. pulse velocity, dynamic response, acoustic emission, thermography, radar, radioactive methods)
- Some guides are available on NDT of Concrete Structures. (e.g. The [IAEA Guide](#))

Types of Testing Methods

Property to be investigated	Testing Method	Equipment Type
Corrosion of steel reinforcement	<ul style="list-style-type: none"> ➤ Half-cell potential ➤ Resistivity measurement ➤ Cover depth ➤ Carbonation depth ➤ Chloride penetration 	<ul style="list-style-type: none"> ➤ electrical ➤ electrical ➤ electromagnetic ➤ chemical & microscopic ➤ chemical & microscopic

Checking Concrete Cover – The Covermeter



Testing for Corrosion



Phenolphthalein Test for Carbonation



Half Cell Potential Measurement Device



Resistivity Test Device



Portable Chloride Test

Types of Testing Methods

Property to be investigated	Testing Method	Equipment Type
Concrete quality, durability and deterioration	<ul style="list-style-type: none"> ➤ Surface hardness ➤ UPV ➤ Radiography ➤ Radiometry ➤ Permeability test ➤ Absorption test ➤ Moisture test ➤ Petrographic ➤ Sulphate content ➤ Expansion ➤ Air content ➤ Cement type & content ➤ Abrasion resistance 	<ul style="list-style-type: none"> ➤ mechanical ➤ electronic ➤ radioactive ➤ radioactive ➤ hydraulic ➤ hydraulic ➤ chemical & electronic ➤ microscopic ➤ chemical ➤ mechanical ➤ microscopic ➤ chemical & microscopic ➤ mechanical

The Rebound Hammer



**Conventional
Rebound Hammer**



Calibration Anvil

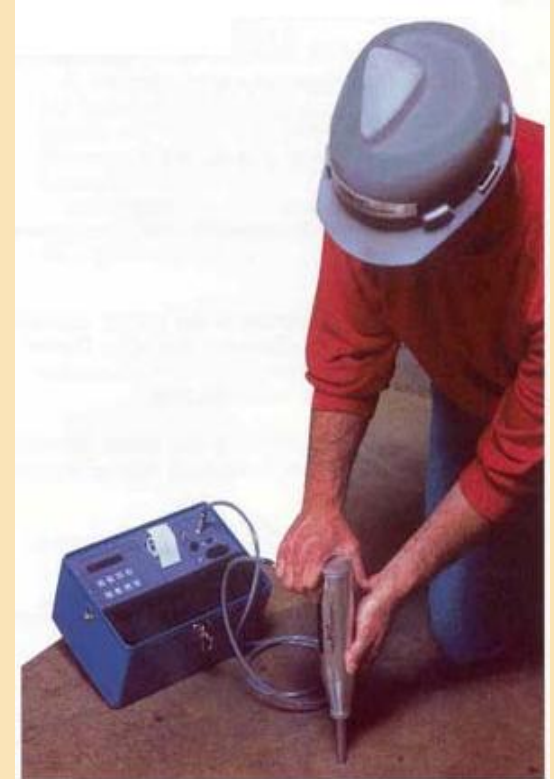

**Digital Rebound
Hammer in Use**

The PUNDIT



The UPV Measurement

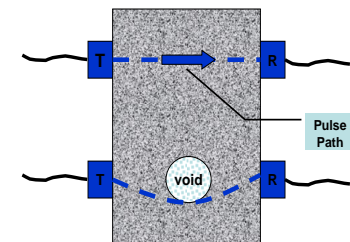

Direct UPV Measurements

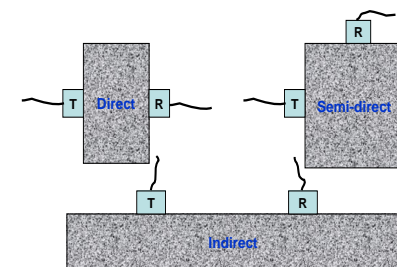

Petrography



Types of Testing Methods

Property to be investigated	Testing Method	Equipment Type
Concrete strength	<ul style="list-style-type: none"> ➤ Cores ➤ Pull-out test ➤ Pull-off test ➤ Break-off test ➤ Internal fracture ➤ Penetration resistance ➤ Maturity test ➤ Temperature match curing 	<ul style="list-style-type: none"> ➤ mechanical ➤ mechanical ➤ mechanical ➤ mechanical ➤ mechanical ➤ mechanical ➤ chemical & electrical ➤ electrical

Core Drilling Machine



Windsor Probe Test



The Windsor HP Probe System.



The Manual Depth Gauge



Pull Out (Lok Test)

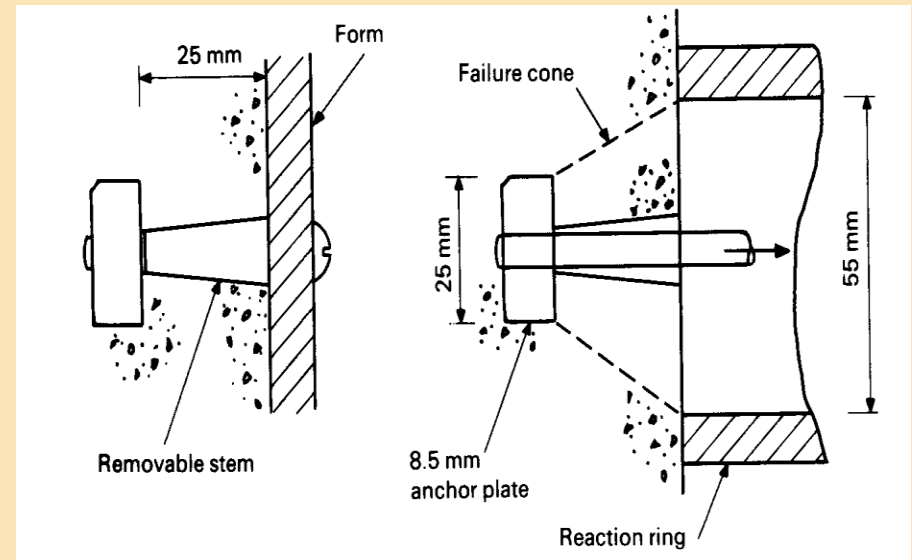

Lok-Test Insert

Pull-Off Test

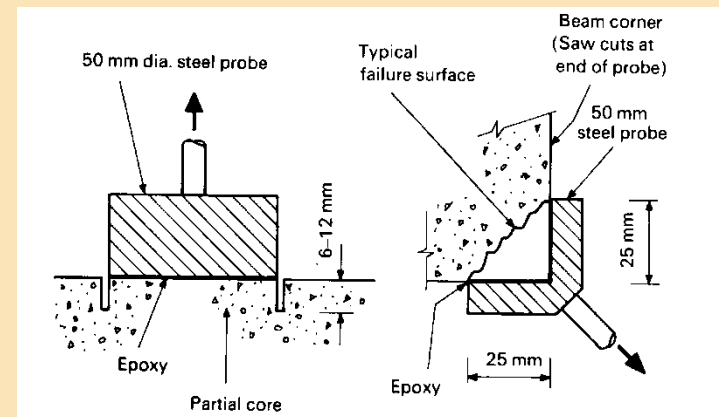

Types of Testing Methods

Property to be investigated	Testing Method	Equipment Type
Integrity and Structural Performance	<ul style="list-style-type: none"> ✱ Tapping ✱ Pulse-echo ✱ Dynamic response ✱ Thermography ✱ Radar ✱ Reinforcement location ✱ Strain / crack measurement ✱ Load test 	<ul style="list-style-type: none"> ➤ mechanical ➤ mechanical & electronic ➤ mechanical & electronic ➤ infra-red ➤ electromagnetic ➤ electromagnetic ➤ Optical / mechanical / electrical ➤ mechanical / electronic / electrical

Pulse Echo / Impact Echo

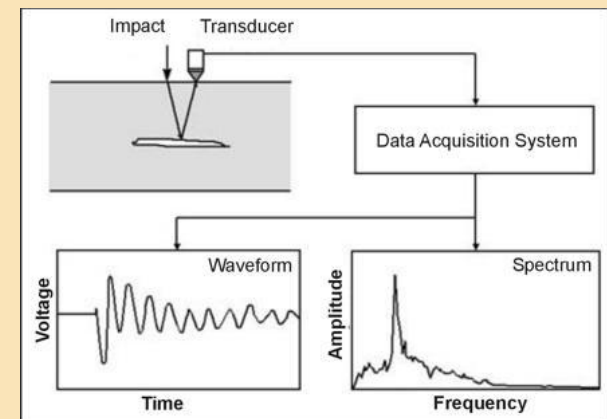
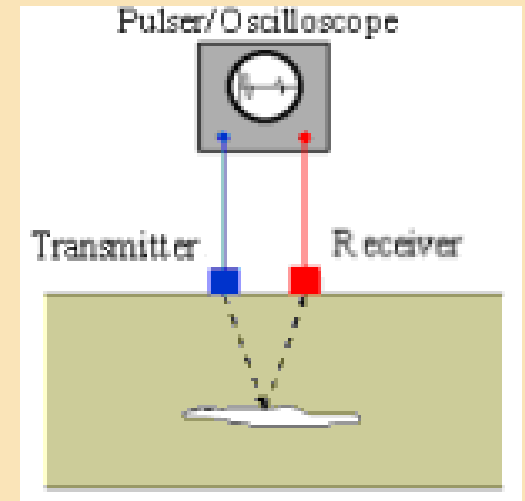

Penetration Radar & Radiography

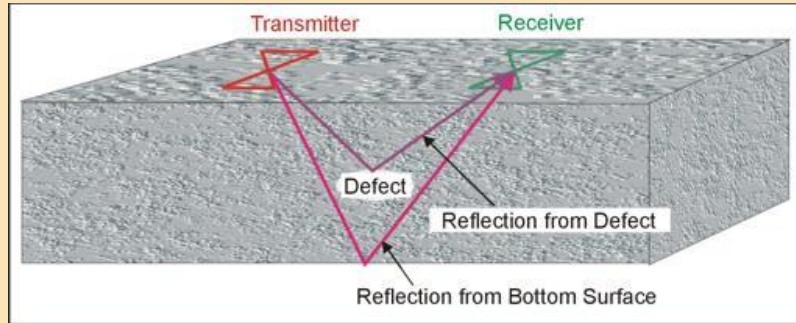

Ground Penetrating Radar system over a defect.

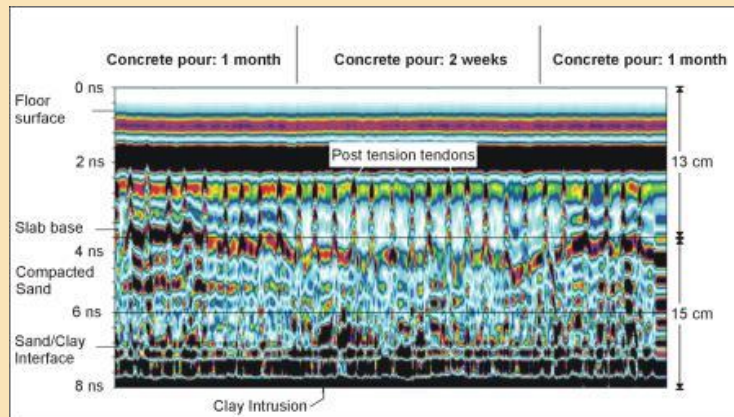

Plot of Ground Penetrating Radar data from a post-tension tendon survey.

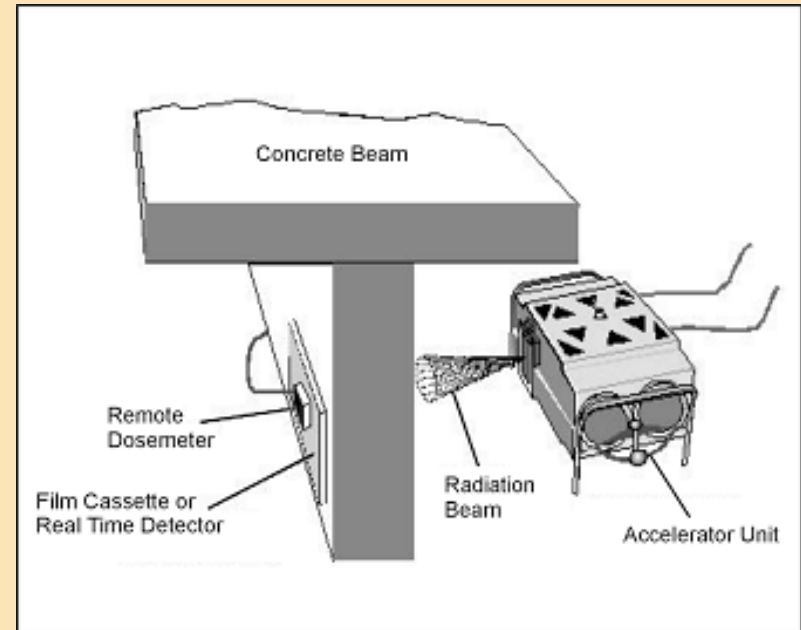

High Energy Radiography equipment and operation

Useful Summary of NDT Techniques

- Inspection and Testing Services Inc. provides a useful summary of NDT techniques for concrete structures.
- Summary of NDT methods ([pdf file](#)) serves as a general guideline and for academic purpose only.

Load Testing on Structures

- Load testing is required when member strength cannot be determined from in-situ material tests;
- Costly & disruptive but psychologically more convincing with positive demonstration of structural capacity;
- Generally for proof of structural capacity;
- Static load tests or dynamic testing for variable loading.

Simple Beam Load Test

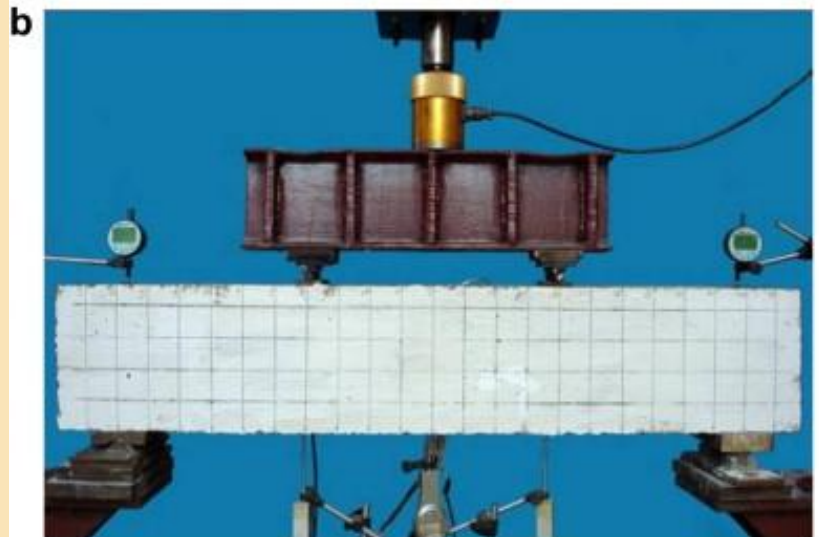
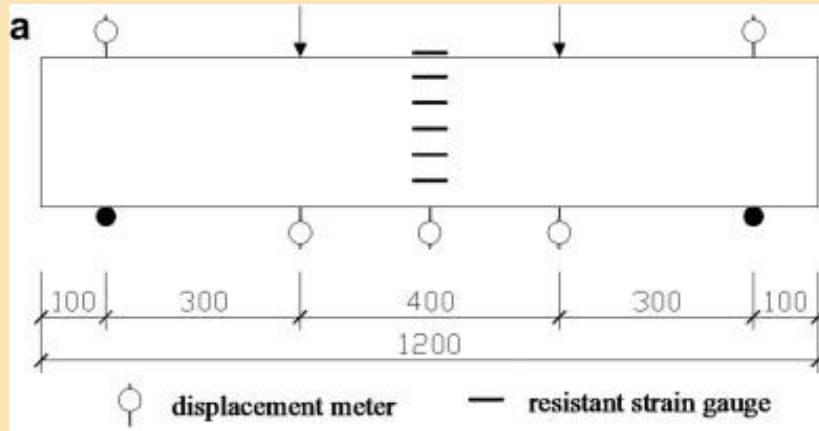

Bridge Beam Load Testing



Bridge undergoing load testing.

Load Testing on Structures

- Typical load testing methods consist of applying uniformly distributed dead loads to the structure in the form of water weights, sand bags, concrete blocks, or similar materials; steel kentledge, reaction frames or simple hydraulic jacks
- These techniques provide an indication of a structure's ability to carry a particular load or complying with certain building regulations or standards.



Load Testing on Floor Slab



Load Testing of Roof Slab



Category of Load Test

- Testing falls into two main categories: **Routine Verification** or **Change of Use**.
- When there is a change in use of a building or a building element shows suspect performance, then testing will be required to establish performance; examples of change of use could be refurbishment of warehousing to residential use, the addition of an extra level to an office block or re assignment of storage for heavy items.

Planning Structural Investigation

- Begins with the purpose – this will influence numbers & locations of test points, types of methods & interpretation procedures.
- Positioning & interpretation of tests must take account variations in properties and difference between in-situ & standard parameters.
- Degree of ‘representativeness’ of surface data.
- Documentation should always be prepared on the basis that litigation may follow.
- Photographic record is valuable.

Overview of Inspection, Testing & Assessment

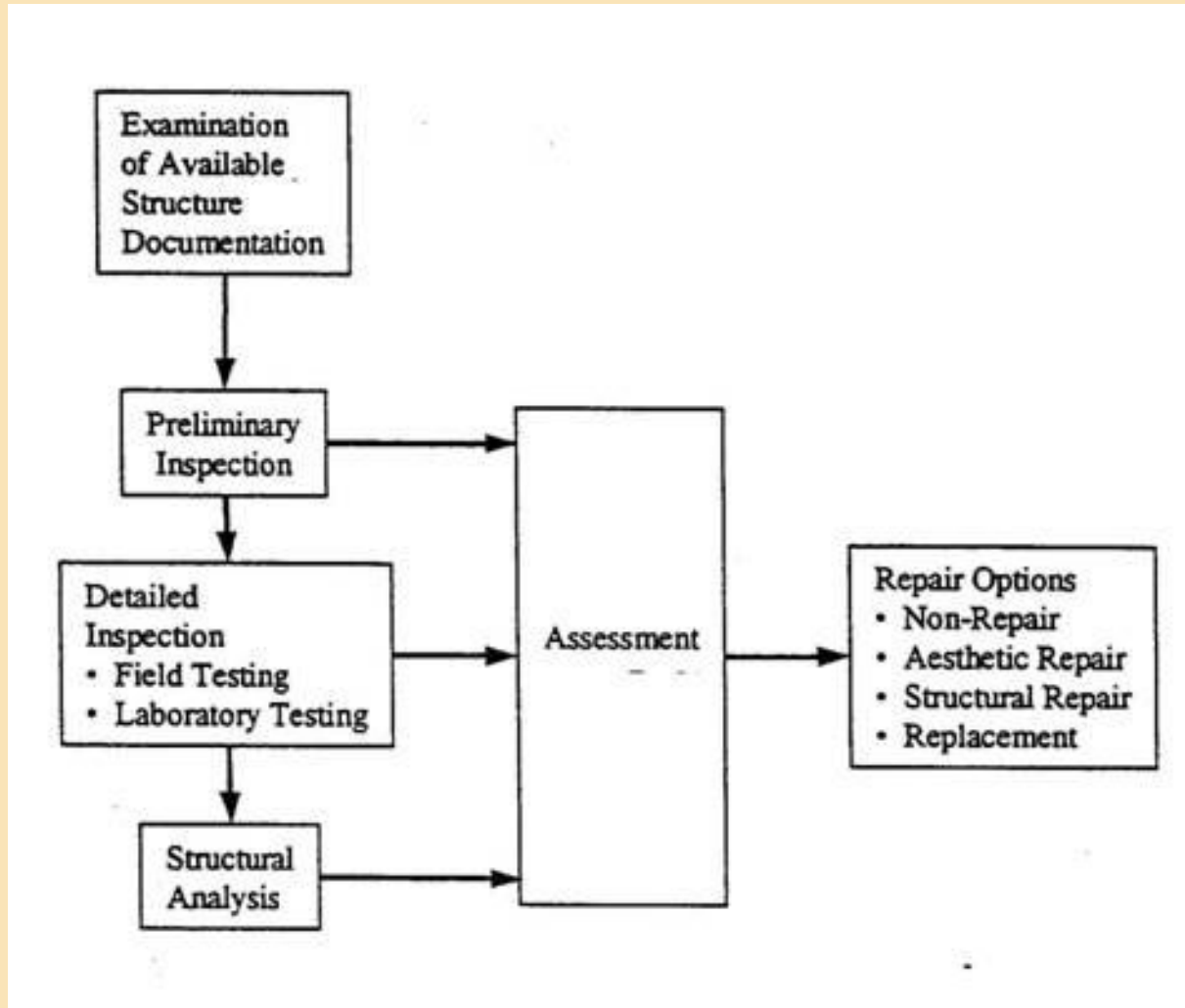

Process Flow of Structural Investigation

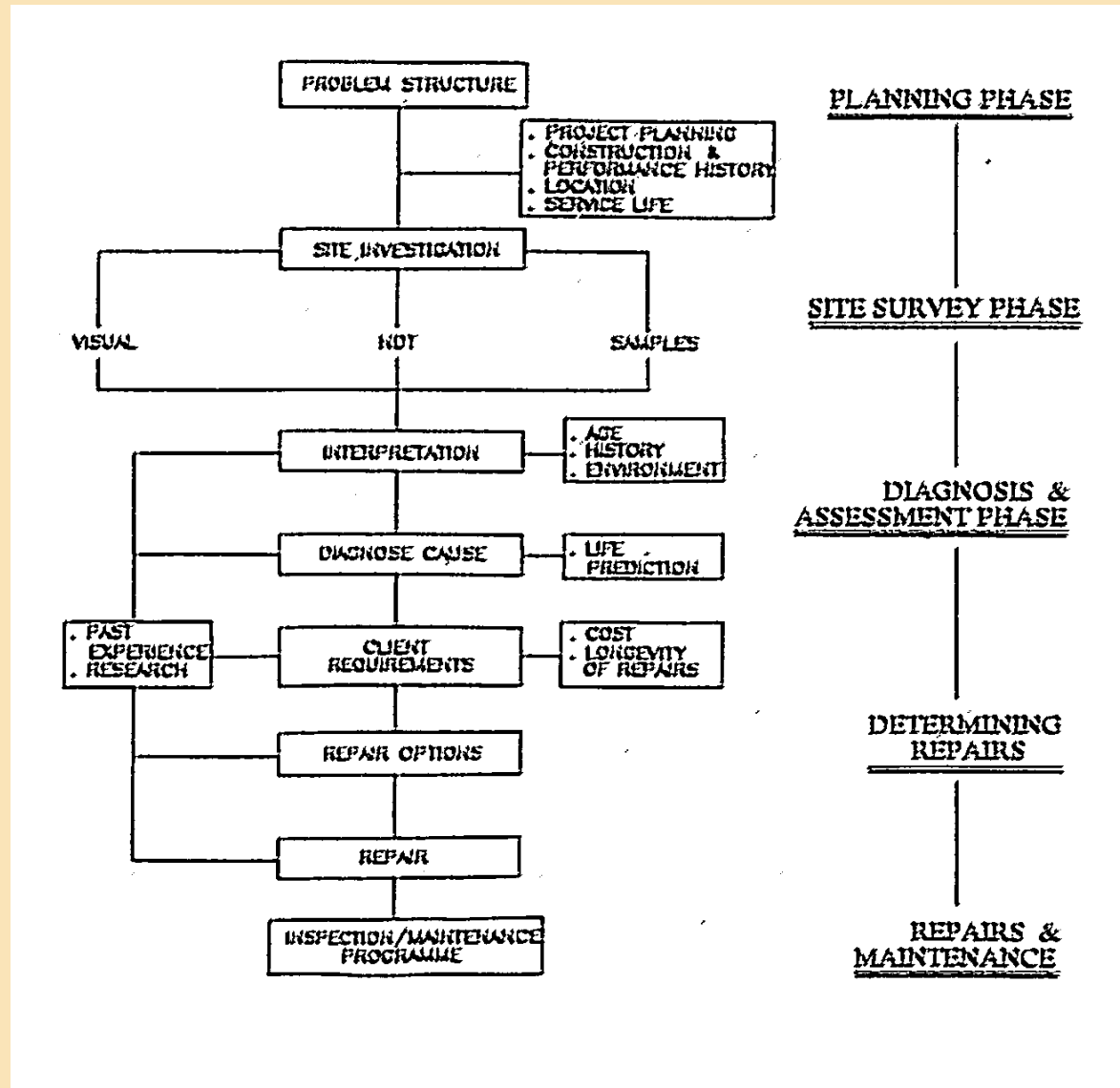

Stages of Testing Programme

Stage 1 : Planning

- Establish aims & information required.
- Documentation survey (desk study).
- Preliminary site visit (access & safety).
- Agreed interpretation criteria & procedure.
- Systematic visual inspection – initial test selection & costing.
- Analysis & interpretation of results.

Stages of Testing Programme

Stage 2 : Non-Destructive Testing

- Comparative condition survey.
- Calibrated assessment.
- Analysis, laboratory tests & interpretation of results.

Stages of Testing Programme

Stage 3 : Further / detailed testing

- Localised investigation (cores, etc.)
- Laboratory tests.
- Load testing (where applicable).
- Analysis & interpretation of results.

Stages of Testing Programme

Stage 4 : Reporting of results

- Conclusions on findings.
- Documentation of results.
- Recommendations for remedial measures.
- Propose repair specifications (where applicable).

Selection of Test Method

Basis for selection of test methods :

- The nature of information required.
- The availability reliability of correlations.
- The effects & acceptability of surface damage.
- Practical limitations: e.g. member size & type, surface condition, depth of test zone, location of reinforcement bar, accessibility of test points.
- Economic considerations of the value of work & cost of delays in relation to total cost of test programme.

Selection of Test Method

- BS1881 Part 201 (1986) – provides detailed guidance on selection of test method and planning of investigation.
- Recommended to use test combinations (either one test as a prelim to other or using different methods to complement each other)
- e.g. combination of half-cell potentials, resistivity, carbonation depth & chloride penetration assessment will improve confidence in results.

Selection of Test Method

- Proper visual inspection is important : examination of crack patterns gives useful information. Use survey proformas to record defects etc.
- Concrete Society Technical Report 22 for guidance on identification of crack types.
- ACI Code 201 – comprehensive list of 38 types of defects with photographs.
- Systematic crack mapping over a period of time provides valuable information for determining causes & progression of deterioration.

Condition Survey : Crack Mapping & Recording Defects

- Crack mapping over a period of time to assess nature, extent & probable causes.
- Use of proformas to record crack locations & directions on grids.
- Simple instrumentation : tell-tale glass, demec gauge points to record movements.
- Live cracks/dead cracks. Structural or non-structural cracks.
- [Recording of Defects.doc](#)
- [Condition rating](#) system may also be used to facilitate recording and reporting.

Crack Monitoring (Demec Gauge)

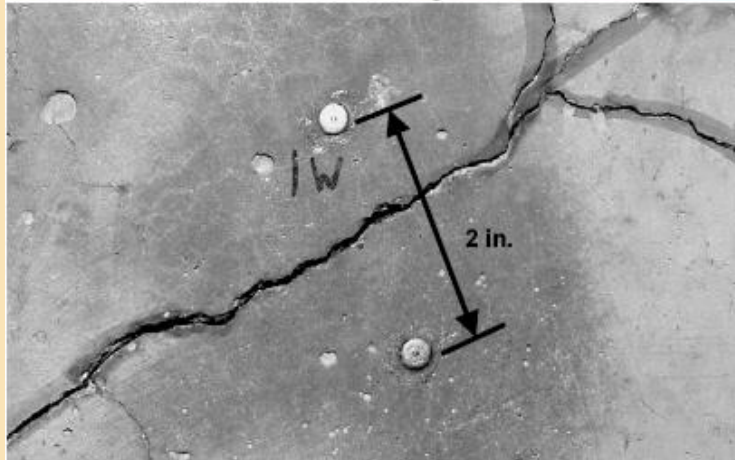

Crack Measurement by DEMEC



Crack Monitoring (Tell-Tale Glass)

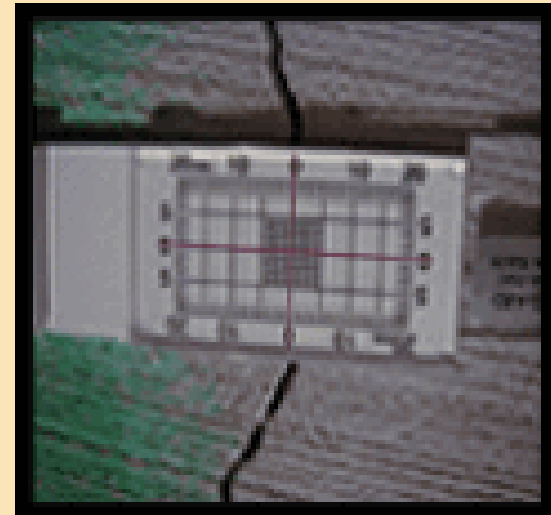
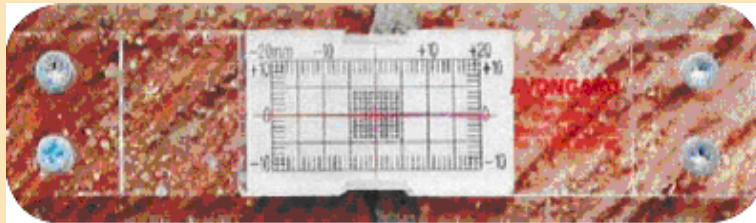
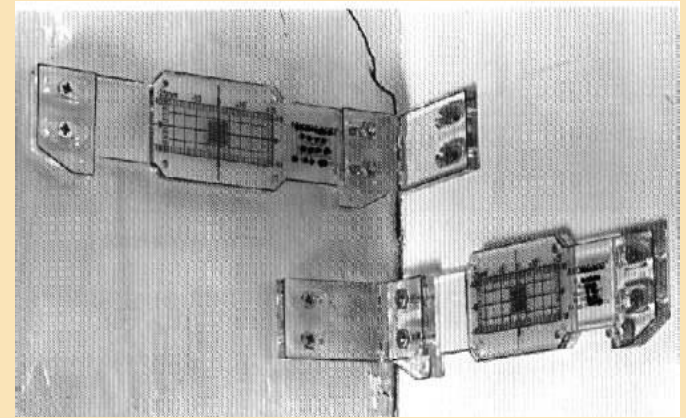
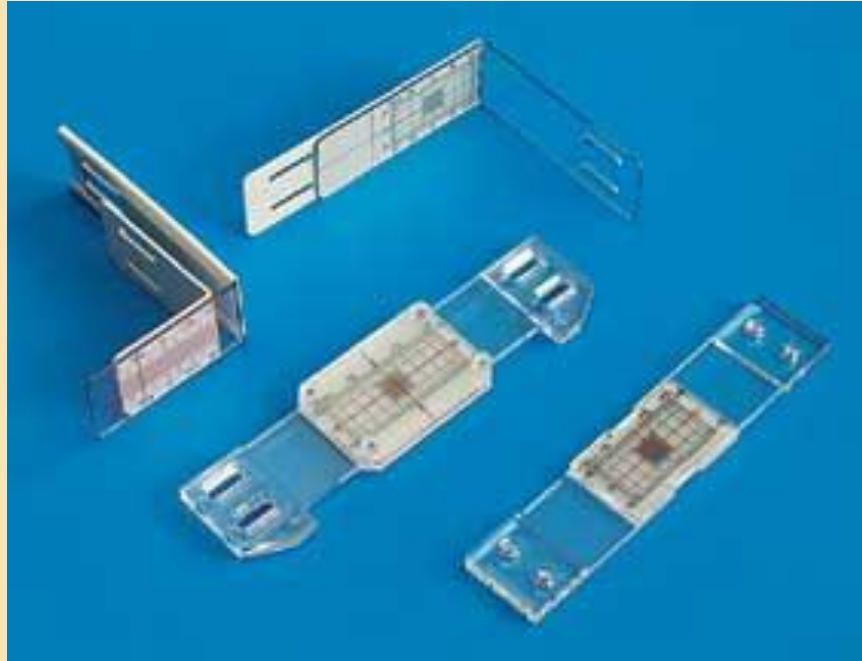

Crack Measurement



Selection of Test Method

- Preliminary comparative surveys using simple NDT methods are useful in investigation related to materials properties condition assessment.
- e.g. The use of rebound hammer & UPV to establish locations for coring or partially-destructive tests.
- The nature of information required & aims of investigation will influence choice of test method as well as interpretation procedures. These must be agreed by all parties before testing commences.

Selection of Test Method – points to consider

- All tests have limitations : repeatability, accuracy level & access requirements.
- Cost factor.
- Localised damage.
- Indirect measurement needs correlation between test results & the measured parameter.
- All test equipment must be calibrated.
- Requires skilled technician to carry out testing.

Selection of Test Method – points to consider

- Majority of tests are effective when used on a comparative basis.
- Be aware of the levels of accuracy of prediction when measuring absolute values e.g. strength.
- Contour plots (e.g. UPV etc.) are useful aid to interpretation.
- Ensure sufficient tests for ‘representativeness’ of material under investigation.
- Proper planning and execution of test should be comprehensive enough to be of practical relevance.

Standards for Inspection, Testing and Repair - British Standards for Concrete Testing (BSI)

BS 1881: Methods of Testing Concrete

- Part 5: 1970 Methods of testing hardened concrete for other than strength
- Analysis of hardened concrete
- Part 105: 1984 Method for determination of flow
- Part 108: 1983 Method of making test cubes from fresh concrete
- Part 111: 1983 Method of normal curing of test specimens
- Part 116: 1983 Method for determination of compressive strength of concrete cubes
- Part 120: 1983 Method for determination of the compressive strength of concrete cores
- Part 201: 1986 Guide to the use of non-destructive methods of test for hardened concrete

Standards for Inspection, Testing and Repair - British Standards & others

- Part 202: 1986 Recommendations for surface hardness testing by rebound hammer
- Part 203: 1986 Measurement of the velocity of ultrasonic pulses in concrete
- Part 204: 1988 Recommendations on the use of electromagnetic covermeters
- BS 4551: 1980 Methods of testing mortars screeds and plasters.
- ASTM C876 Method for Half-Cell Potentials of Uncoated Reinforcing Steel in Concrete.
- CP 25/77: A simple pull out test to assess the strength of in-situ concrete.
- IP 21/86: Determination of chloride and cement of hardened concrete.

Standards for Inspection, Testing and Repair –

TRRL Publications

- LR 953: A survey of site tests for the assessment of corrosion in reinforced concrete, by P R Vassie
- LR 981: Case studies of the corrosion of reinforcement in concrete structures. R J Woodward.
- AG3: Microprocessor controlled multiple half-cell measurements. M A Winnett.
- RR 81: Repair of cracked concrete: assessment of injection methods. A J Calder.
- RR 150: Repair of cracked concrete: assessment of corrosion protection. A J Calder and D M Thompson.
- RR 109: Durability of concrete repairs: the effect of steel cleaning procedures. P R Vassie.
- The half-cell method of locating corroding reinforcement in concrete structures. Application Guide 9. P R Vassie.

Standards for Assessment

- BD 44 The Assessment of Concrete Highway Bridges and Structures. (DMRB 3.4.14).
- BA 38 Assessment of the Fatigue Life of Corroded or Damaged Reinforcing Bars. (DMRB 3.4.5)
- BA 39 Assessment of Reinforced Concrete Half Joints. (DMRB 3.4.6)
- BA 51 The Assessment of Concrete Structures Affected by Steel Corrosion. (DMRB 3.4.13)
- BA 52 The Assessment of Structures affected by Alkali-Silica Reaction. (DMRB 3.4.10).

Structural Investigation Report

- Report is the final product the client sees;
- A valuable step in the investigative plan;
- Information from several team members brought together;
- Writer need to organise and review all issues.

Basic Components of Structural Investigation Report

- Letter of transmittal
- Executive summary / abstract
- Introduction : objectives, scope, background, desk study documents (listing)
- Description of the structure
- Field Investigation
- Laboratory tests
- Results of calculations
- Discussion of results
- Conclusions
- Recommendations : based on conclusions; options with estimated costs

Reporting : Letter of transmittal

- Cover letter to client;
- Explain briefly the submission of the report.
- Summarise previously agreed upon objectives.
- Make specific recommendations or to request action.

Reporting : Executive Summary

- Limited to 1 page.
- Concise description of the project.
- Explain objectives, findings & final recommendations.
- Describe briefly what the report covers and summary of principal conclusions.

Reporting : Introduction

- Objectives of investigation : TOR agreed with client and emphasize why the investigation was undertaken.
- Scope of investigation : define area of investigation & what work was to be performed. Present methodology.
- Background : history of development of project.
- Desk study : listing of contents of relevant documents, drawings etc. used or referred to.

Reporting : Description of the Structure

- A detailed description of the structure being investigated : name, type, structural forms/systems, principal dimensions, location, special features, relevant historical data, change of use etc.
- [Examples.](#)

Reporting : Field Investigation

- Include facts and observations of all in-situ tests carried out.
- Description of the tests, dates of tests & name of personnel involved.
- Present results of in-situ tests.

Reporting : Laboratory Tests

- Present all laboratory test results but not the interpretation of the results.

Reporting : Results of Calculations

- Results of analysis and calculations is presented with no interpretation yet.

Reporting : Discussion of Results

- Contains interpretation of findings & opinions based on the results of field investigation, laboratory tests & calculations.
- Discussions should be based on factual information presented in previous sections.

Reporting : Conclusions

- Conclusions should flow logically from, and be supported by, the discussions.
- Use numbered or bulleted list of items.

Reporting : Recommendations

- Should be based on the conclusions.
- Suggest various options to the client for consideration.
- Propose most preferred option with supporting arguments including costs implications.
- Specifications for remedial work (separate requirements).

Concluding Remarks



- Structural testing / NDT will not, of itself make judgements, but in many cases, it will help to ensure that judgements are sound.
- Assessment techniques must be supported by :
 - an appreciation of material properties;
 - good structural awareness;
 - an interchanging of knowledge & experience between the TESTER and the ENGINEER.

Terima Kasih